

Unica Styling Chair
Model # MI-4070

PARTS LIST

Part	Qty.	Description
A	1	Chair Top
B	1	Base and Hydraulic
C	1	Footrest bar
D	1	Bracket
E	5	Bolt + washer + lock washer

*Open all boxes to check for parts before beginning assembly.

Tools required (included):

Allen wrench (included)

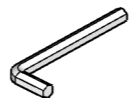

**! ALWAYS KEEP HYDRAULIC BASE UPRIGHT. THE HYDRAULIC SHOULD NOT BE STORED OR TURNED UPSIDE-DOWN!
! SEEK HELP TO DO THIS STEP!**

Assembly instructions:

1

1. Attach the black mounting bracket (D) to the hydraulic base with a bolt. Use a wrench to firmly secure into place.

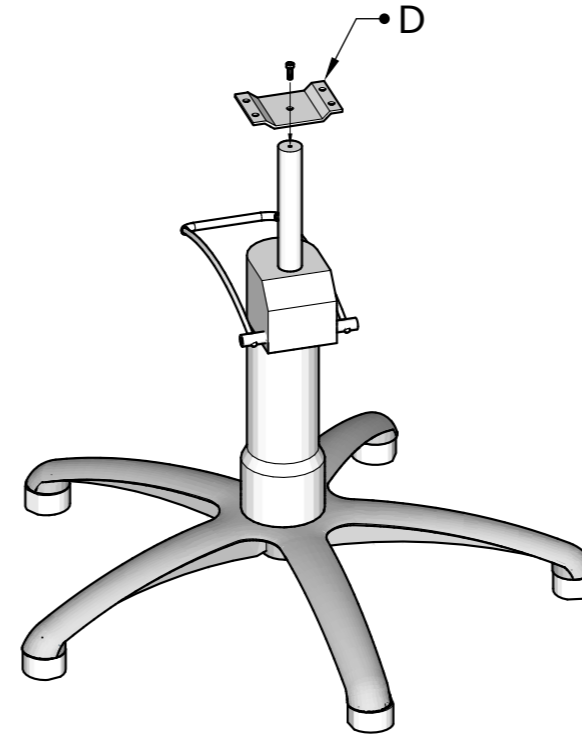

2

1. Two extra sets of hands are best to help keep everything in place. Once help is found, align the chair bracket (D) to the FRONT set of holes on the footrest bar (C). Next, locate the holes found underneath the chair top (A) and hold in place.
2. Ensure the higher part of the base bracket faces toward the front of the chair seat.

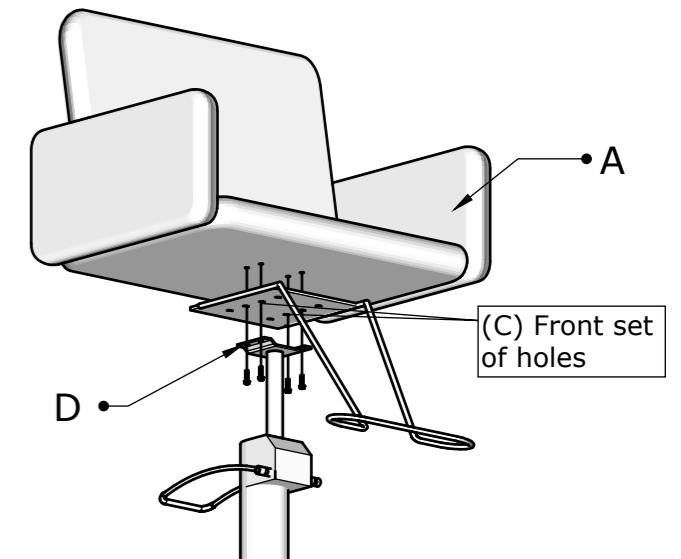

3

1. Secure the base, bracket (D), and footrest (C) to the chair top (A) with 4 bolt/washer sets (E) as shown below. *Pump the hydraulic up higher if necessary to see underneath.
2. Assembly is now complete.

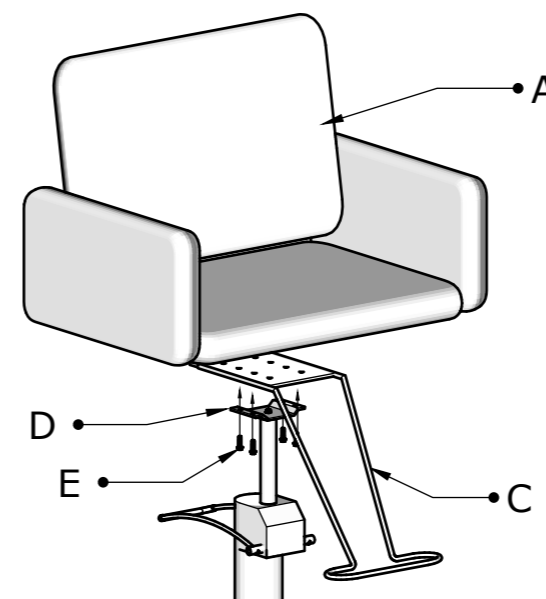

4

Enjoy your new chair

Remember to always keep the hydraulic upright. Also be sure not to stand solely on the footrest.

It is good to pump the hydraulic to full height and back down several times right after assembly to prime the hydraulic fluid. This will keep the pump smooth and responsive.

Note that short quick pumping is more effective than pressing the lever all the way down each time.

If you have any questions or problems during assembly please call our customer service at 1.888.332.0123

Thanks for choosing Minerva!